

## 2-Phase stepper Motor Driver ST-M5045

### Characteristics :

1. DC power input type: 24V~50V
2. Output current: 1~4.5A
3. Microstep: 2、4、8、16、32、64、128、256、5、10、25、50、125、250
4. Protect form : Overheated protect, Short-voltage, over-voltage, over-current protection
5. The maximum pulse rate is 300KHZ.
6. Dimensions: 120mm\*92mm\*33mm
7. Weight: <280g.
8. Working environment: Temperature-15~50°C Humidity<90%。

### I/O Ports :

- 1、 DC+: DC power positive pole

**Note: Must guard against exceeding 50V, so as not to damage the module.**

- 2、 DC-: DC power cathode
- 3、 A+、 A-: Stepping motor one winding
- 4、 B+、 B-: Stepping motor other winding
- 5、 PUL+、 PUL -: Stepping pulse input+5V (Rising edge effective , rising edge duration >10μS)
- 6、 DIR +、 DIR-: Stepping motor direction input, voltage level touched off, high level forward , low level reverse
- 7、 ENA+、 ENA-: motor free

### Typical Connection

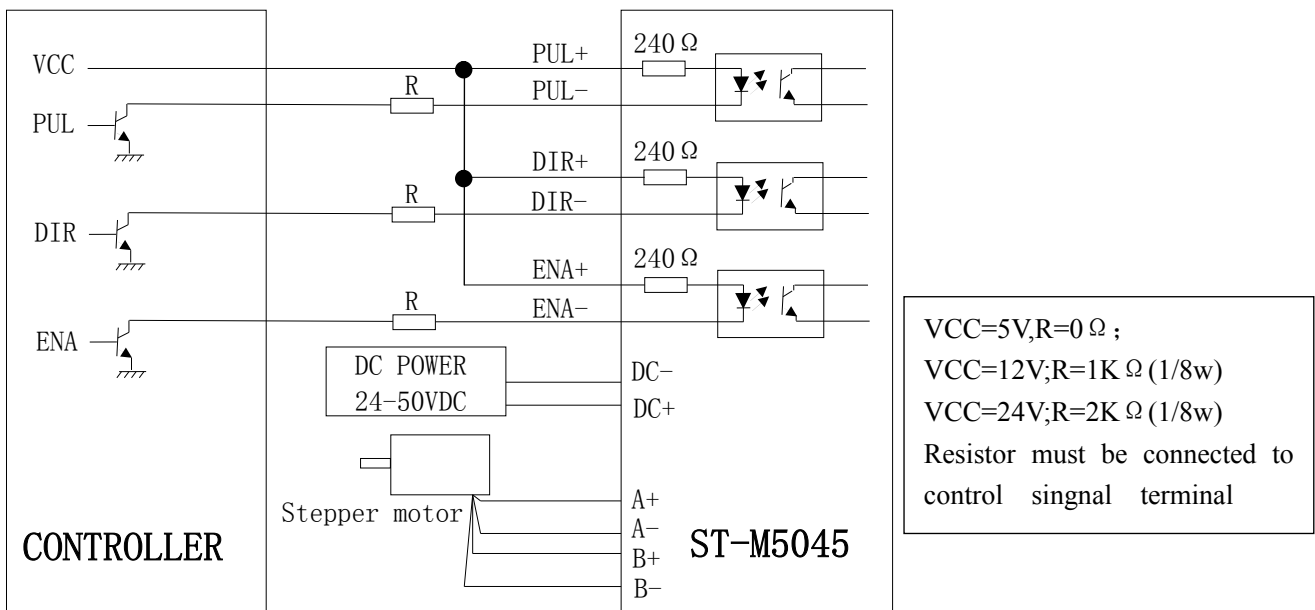

### Switch Choice:

#### 1、 Microstep choice:

Microstep	Pluse/rev. (for 1.8° motor)	SW5	SW6	SW7	SW8
2	400	ON	ON	ON	ON
4	800	ON	OFF	ON	ON
8	1600	ON	ON	OFF	ON
16	3200	ON	OFF	OFF	ON
32	6400	ON	ON	ON	OFF
64	12800	ON	OFF	ON	OFF

128	25600	ON	ON	OFF	OFF
256	51200	ON	OFF	OFF	OFF
5	1000	OFF	ON	ON	ON
10	2000	OFF	OFF	ON	ON
25	5000	OFF	ON	OFF	ON
50	10000	OFF	OFF	OFF	ON
125	25000	OFF	ON	ON	OFF
250	50000	OFF	OFF	ON	OFF

**2、 Current choice:**

Peak current	Reference current	SW1	SW2	SW3
1. 0A	0. 71A	ON	ON	ON
1. 5A	1. 07A	OFF	ON	ON
2. 0A	1. 43A	ON	OFF	ON
2. 5A	1. 79A	OFF	OFF	ON
3. 0A	2. 14A	ON	ON	OFF
3. 5A	2. 50A	OFF	ON	OFF
4. 0A	2. 86A	ON	OFF	OFF
4. 5A	3. 21A	OFF	OFF	OFF

**3、 Full current or half current choice:**

SW4:OFF=Half current ; ON=Full current;

**Dimension**

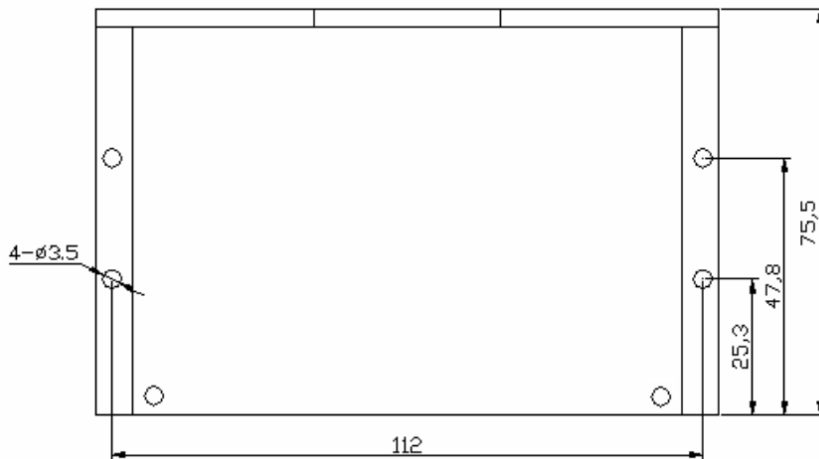
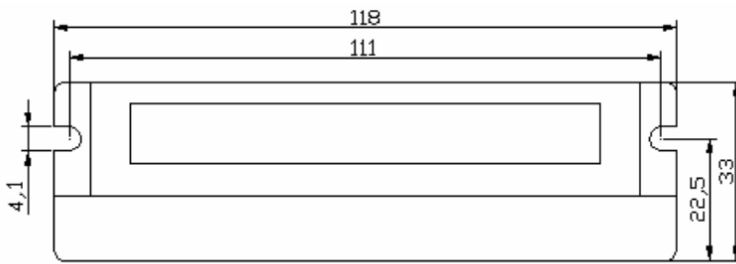

**Note:**

1. When the drive is powered, do not plug terminals and operating switch;
2. Ensure that the driver has good cooling conditions and prevent dust entering the electronic control box;