

User's Manual-M542H

Stepper Motor Driver

Version 1.0

2006 All Rights Reserved

Attention: Please read this manual carefully before using the driver!



Sunwind Electronics Company Ltd.

Add:7th Floor,Block H,Juyin Industrial Park,Ganli Road 1#,Buji,Shenzhen,China.

Homepage:<http://www.steppmotordriver.com> E-mail:info@steppmotordriver.com

Phone:0086 755 86610835

Fax: 0086 755 86610201

The content in this manual has been carefully prepared and is believed to be accurate, but no responsibility is assumed for inaccuracies.

Sunwind reserves the right to make changes without further notice to any products herein to improve reliability, function or design. Sunwind does not assume any liability arising out of the application or use of any product or circuit described herein; neither does it convey any license under its patent rights of others.

Sunwind's general policy does not recommend the use of its products in life support or aircraft applications wherein a failure or malfunction of the product may directly threaten life or injury. According to Sunwind's terms and conditions of sales, the user of Sunwind's products in life support or aircraft applications assumes all risks of such use and indemnifies Sunwind against all damages.

2006 by Sunwind Electronics Company Limited

All Rights Reserved

Table of Contents

1. Introduction, Features and Applications.....	5
Introduction	5
Features	5
Applications.....	5
2. Specifications and Operating Environment	6
Electrical Specifications	6
Operating Environment and other Specifications	6
Mechanical Specifications.....	7
3. Pin Assignment and Description.....	8
Connector P1 Configurations.....	8
Connector P2 Configurations.....	9
4. Control Signal Connector (P1) Interface.....	9
5. Connecting the Motor	10
Connections to 4-lead Motors.....	10
Connections to 6-lead Motors.....	11
Half Coil Configurations.....	11
Full Coil Configurations	11
Connections to 8-lead Motors.....	12
Series Connections.....	12
Parallel Connections.....	12
6. Power supply Selection	13

Regulated or Unregulated Power Supply	13
Multiple Drivers.....	14
Selecting Supply Voltage.....	14
7. Selecting Microstep Resolution and Driver Output Current.....	14
Microstep Resolution Selection	15
Current Settings	15
Dynamic Current Setting	15
Standstill Current Setting.....	16
8. Wiring Notes.....	16
9. Typical Connection	17
10. Sequence Chart of Control Signals.....	17
11. Protection Functions.....	18
Over-voltage Protection.....	18
Coil-ground Short Circuit Protection	19
12. Frequently Asked Questions.....	19
Problem Symptoms and Possible Causes	19
APPENDIX.....	20
Twelve Month Limited Warranty	20
Exclusions	20
Obtaining Warranty Service.....	20
Warranty Limitations.....	21
Shipping Failed Product	21

1. Introduction,Features and Applications

Introduction

The M542H is an economical microstepping driver based on patented technology of Sunwind. It is suitable for driving 2-phase and 4-phase hybrid stepping motors. By using the advanced bipolar constant-current chopping technique, it can output more speed and torque from the same motor,compared with traditional drivers, such as L/R drivers. Its 3-state current control technology allows coil currents to be well controlled and with relatively small current ripple, therefore less motor heating is achieved.

Features

- Low cost and good high-speed torque
- Supply voltage up to +100VDC
- Output current up to 4.5A
- Pulse frequency up to 300 KHz
- 3-state current control technology
- Suitable for 2-phase and 4-phase motors
- Over-voltage and short-circuit protection
- Automatic idle-current reduction
- 16 selectable resolutions
- DIP switch current setting with 8 different values
- CW/CCW mode available (optional)
- Optically isolated input signals
- Slim size (118x75.5x33mm)

Applications

Suitable for a wide range of stepping motors from NEMA size 17 to 34. It can be used in various kinds of

machines, such as X-Y tables, labeling machines, laser cutters, engraving machines,pick-place devices, and so on. Particularly adapt to the applications desired with low vibration,high speed and high precision.

2.Specifications and Operating Environment

Electrical Specifications(Tj=25°C)

Parameters	DM542H			
	Min	Typical	Max	Unit
Output Current	1.00	-	5.00 (3.0 RMS)	A
Input Voltage	+20	+50	+100	VDC
Logic Signal Current	7.00	10	16	Ma
Pulse input frequency	0.00	-	300	KHz
PulseWidth	2.50	-	-	Us
Pulse Voltage	5.00	-	24	VDC
Isolation resistance	500.00			MΩ

Operating Environment and other Specifications

Cooling	Natural Cooling or Forced cooling	
Operating Environment	Environment	Avoid dust, oil fog, conosive gases
	Ambient Temperature	0°C — 50°C
	Humidity	40%RH — 90%RH
	Operatiing Temperature	70°C Max
	Vibration	5.9m/s2 Max
Storage Temperature	-20°C — 65°C	
Weight	280gram(9.9oz)	

Mechanical Specifications (unit:mm, 1 inch = 25.4 mm)

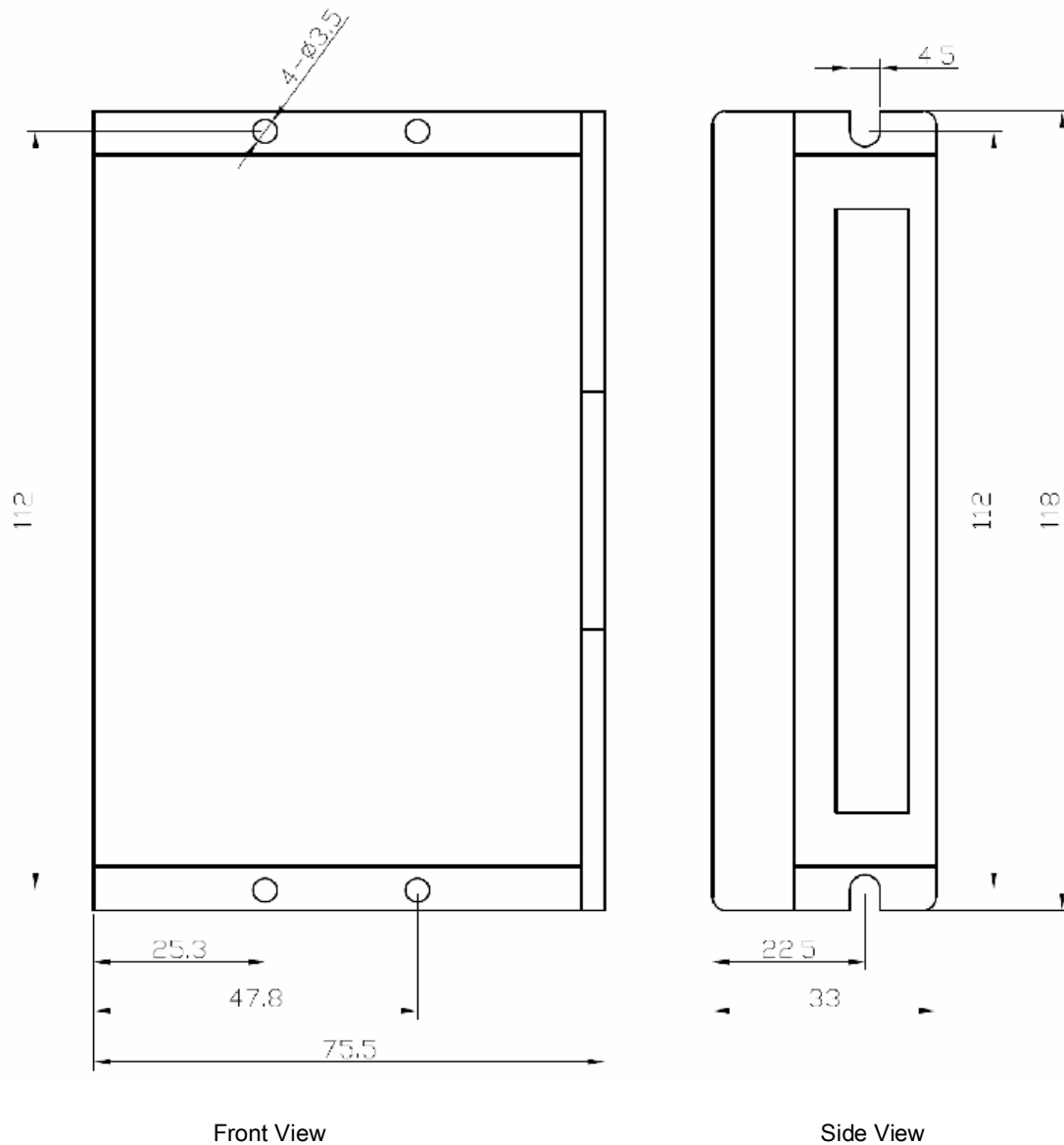

Figure 1: Mechanical specifications

***Recommended to use side mounting for better heat dissipation**

Elimination of Heat

Driver's reliable working temperature should be $<65^{\circ}\text{C}$, and motor working temperature should be $<80^{\circ}\text{C}$;

It is recommended to use automatic idle-current reduction mode, namely current automatically reduce to 60% when motor stops, so as to reduce driver heating and motor heating;

It is recommended to side mounting to maximize heat sink area.

3.Pin Assignment and Description

The M542H has two connectors, connector P1 for control signals connections, and connector P2 for power and motor connections. The following tables are brief descriptions of the two connectors of the M542H.

Connector P1 Configurations

Pin Function	Details
PUL+(+5V)	Pulse signal: In single pulse pulse/direction) mode, this input represents pulse signal, effective for each rising or falling edge (set by inside jumpers in JP1); 4-5V when PUL-HIGH, 0-0.5V when PUL-LOW. In double pulse mode (pulse/pulse) , this input represents clockwise (CW) pulse, effective for high level or low level (set by inside jumpers in JP1). For reliable response, pulse width should be longer than 1.5μ s. Series connect resistors for current-limiting when +12V or +24V used.
PUL-(PUL)	
DIR+(+5V)	DIR signal: In single-pulse mode, this signal has low/high voltage levels, representing two directions of motor rotation; in double-pulse mode (set by inside jumper J3), this signal is counter-clock (CCW) pulse, effective for high level or low level (set by inside jumper J1). For reliable motion response, DIR signal should be ahead of PUL signal by 5μ s at least. 4-5V when DIR-HIGH, 0-0.5V when DIR-LOW.
DIR-(DIR)	
ENA+(+5V)	Enable signal: This signal is used for enabling/disabling the driver. High level (NPN control signal, PNP and Differential control signals are on the contrary, namely Low level for enabling.) for enabling the driver and low level for disabling the driver. Usually left UNCONNECTED (ENABLED).
ENA-(ENA)	

Single pulse and double pulses mode switch

There are two jumpers inside the M542H specifically for switch Single pulse and double pulses mode, as shown in figure 2. Default setting is Single pulse mode.

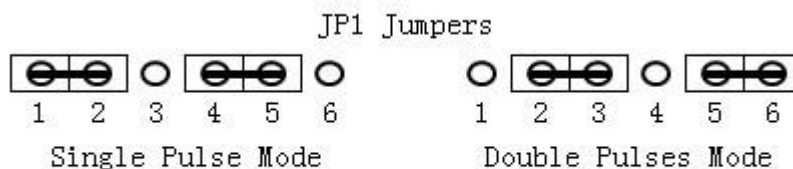

Figure 2:Single pulse/double pulses mode switch

Connector P2 Configurations

Pin Function	Details
GND	DC power ground
+V	DC power supply, DC20~100V, Including voltage fluctuation and EMF voltage.
A+, A-	Motor Phase A
B+, B-	Motor Phase B

4. Control Signal Connector (P1) Interface

The M542H can accept differential and single-ended input signals (including open-collector and PNP output). The M542H has 3 optically isolated logic inputs which are located on connector P1 to accept line driver control signals. These inputs are isolated to minimize or eliminate electrical noises coupled onto the drive control signals. Recommend use line driver control signals to increase noise immunity of the driver in interference environments. In the following figures, connections to open-collector and PNP signals are illustrated.

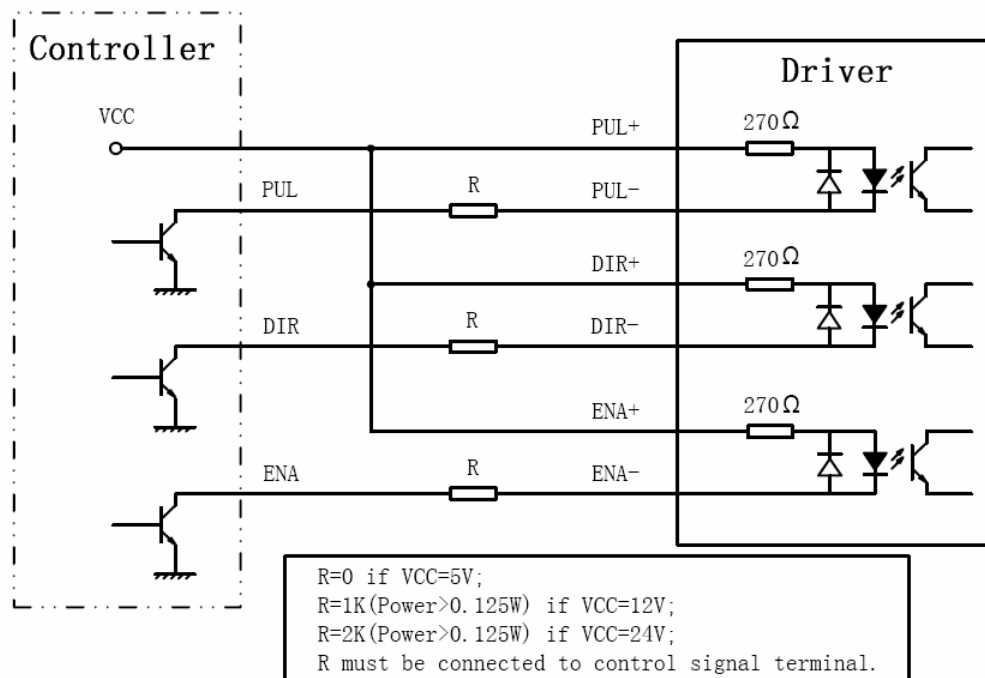

Figure 3: Connections to open-collector signal (common-anode)

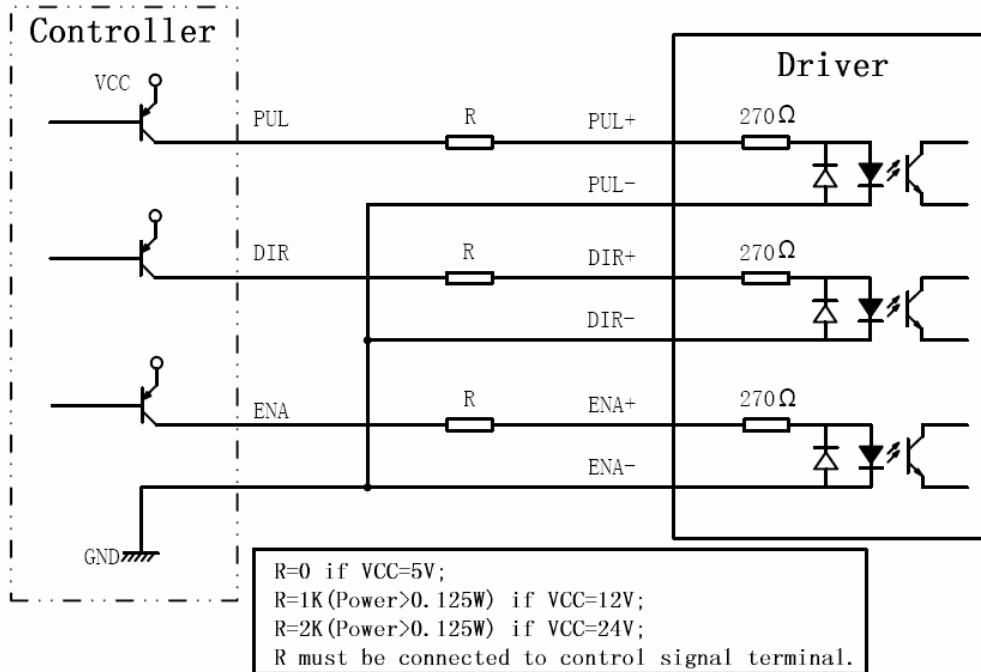

Figure 4: Connection to PNP signal (common-cathode)

5. Connecting the Motor

The M542H driver can drive any 2-phase and 4-phase hybrid stepping motors.

Connections to 4-lead Motors

4 lead motors are the least flexible but easiest to wire. Speed and torque will depend on winding

inductance. In setting the driver output current, multiply the specified phase current by 1.4 to

determine the peak output current.

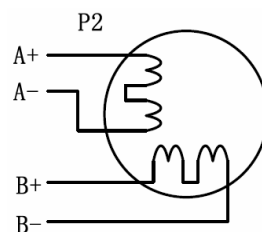

Figure 5: 4-lead Motor Connections

Connections to 6-lead Motors

Like 8 lead stepping motors, 6 lead motors have two configurations available for high speed or high torque operation. The higher speed configuration, or half coil, is so described because it uses one half of the motor's inductor windings. The higher torque configuration, or full coil, uses the full windings of the phases.

Half Coil Configurations

As previously stated, the half coil configuration uses 50% of the motor phase windings. This gives lower inductance, hence, lower torque output. Like the parallel connection of 8 lead motor, the torque output will be more stable at higher speeds. This configuration is also referred to as half chopper. In setting the driver output current multiply the specified per phase (or unipolar) current rating by 1.4 to determine the peak output current.

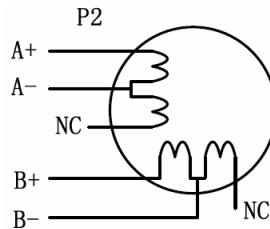

Figure 6: 6-lead motor half coil (higher speed) connections

Full Coil Configurations

The full coil configuration on a six lead motor should be used in applications where higher torque at lower speeds is desired. This configuration is also referred to as full copper. In full coil mode, the motors should be run at only 70% of their rated current to prevent over heating.

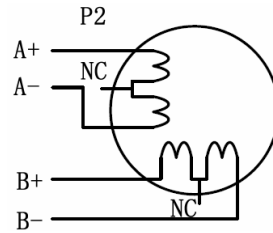

Figure 7: 6-lead motor full coil (higher torque) connections

Connections to 8-lead Motors

8 lead motors offer a high degree of flexibility to the system designer in that they may be connected in series or parallel, thus satisfying a wide range of applications.

Series Connections

A series motor configuration would typically be used in applications where a higher torque at lower speeds is required. Because this configuration has the most inductance, the performance will start to degrade at higher speeds. In series mode, the motors should also be run at only 70% of their rated current to prevent over heating.

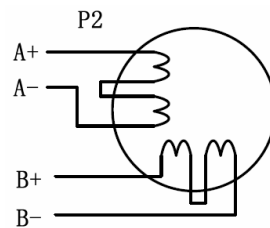

Figure 8: 8-lead motor series connections

Parallel Connections

An 8 lead motor in a parallel configuration offers a more stable, but lower torque at lower speeds. But because of the lower inductance, there will be higher torque at higher speeds. Multiply the per phase (or unipolar) current rating by 1.96, or the bipolar current rating by 1.4, to determine the peak output current.

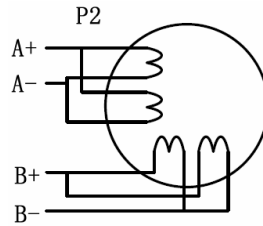

Figure 9: 8-lead motor parallel connections

6. Power supply Selection

The M542H can match medium and small size stepping motors (from Nema size 17 to 34) made by Sunwind or other motor manufactures around the world. To achieve good driving performances, it is important to select supply voltage and output current properly. Generally speaking, supply voltage determines the high speed performance of the motor, while output current determines the output torque of the driven motor (particularly at lower speed). Higher supply voltage will allow higher motor speed to be achieved, at the price of more noise and heating. If the motion speed requirement is low, it's better to use lower supply voltage to decrease noise, heating and improve reliability.

Regulated or Unregulated Power Supply

Both regulated and unregulated power supplies can be used to supply the driver. However, unregulated power supplies are preferred due to their ability to withstand current surge. If regulated power supplies (such as most switching supplies.) are indeed used, it is important to have large current output rating to avoid problems like current clamp, for example using 4A supply for 3A motor-driver operation. On the other hand, if unregulated supply is used, one may use a power supply of lower current rating than that of motor (typically 50% ~ 70% of motor current). The reason is that the driver draws current from the power supply capacitor of the unregulated supply only during the ON duration of the PWM cycle, but not during

the OFF duration. Therefore, the average current withdrawn from power supply is considerably less than motor current. For example, two 3A motors can be well supplied by one power supply of 4A rating.

Multiple Drivers

It is recommended to have multiple drivers to share one power supply to reduce cost, if the supply has enough capacity. To avoid cross interference, **DO NOT** daisy-chain the power supply input pins of the drivers. (Instead, please connect them to power supply separately.)

Attention: NEVER connect power and ground in the wrong direction, as it will damage the M542H.

Selecting Supply Voltage

The power MOSFETS inside the M542H can actually operate within +20V - +100VDC, max DC110V, including power input fluctuation and back EMF voltage generated by motor coils during motor shaft deceleration. Higher supply voltage can increase motor torque at higher speeds, thus helpful for avoiding losing steps. However, higher voltage may cause bigger motor vibration at lower speed, and it may also cause over-voltage protection or even driver damage. Therefore, it is suggested to choose only sufficiently high supply voltage for intended applications, and it is suggested to use power supplies with theoretical output voltage of DC+20 ~ + 100V, max DC110V, leaving room for power fluctuation and back-EMF.

7. Selecting Microstep Resolution and Driver Output Current

This driver uses an 8-bit DIP switch to set microstep resolution, and motor operating current, as shown below:

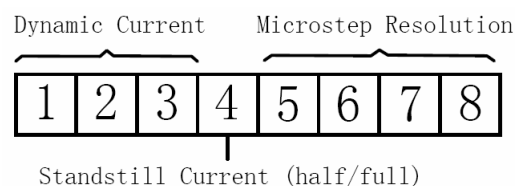

Microstep Resolution Selection

Microstep resolution is set by SW5, 6, 7, 8 of the DIP switch as shown in the following table:

Step Angle	Pulse/Rev	SW5	SW6	SW7	SW8
0.9	400	ON	ON	ON	ON
0.45	800	ON	OFF	ON	ON
0.225	1600	ON	ON	OFF	ON
0.1125	3200	ON	OFF	OFF	ON
0.05625	6400	ON	ON	ON	OFF
0.028125	12800	ON	OFF	ON	OFF
0.014063	25600	ON	ON	OFF	OFF
0.007031	51200	ON	OFF	OFF	OFF
0.36	1000	OFF	ON	ON	ON
0.18	2000	OFF	OFF	ON	ON
0.072	5000	OFF	ON	OFF	ON
0.036	10000	OFF	OFF	OFF	ON
0.0144	25000	OFF	ON	ON	OFF
0.0072	50000	OFF	OFF	ON	OFF

Current Settings

The first three bits (SW1, 2, 3) of the DIP switch are used to set the dynamic current. Select a setting

closest to your motor's required current.

Dynamic Current Setting

Peak current (A)	RMS (A)	SW1	SW2	SW3
1.50	0.71	on	on	on
2.00	1.00	off	on	on
2.40	1.18	on	off	on
2.80	1.35	off	off	on
3.20	1.60	on	on	off
3.70	1.82	off	on	off
4.20	2.10	on	off	off
4.50	2.22	off	off	off

Notes: Due to motor inductance, the actual current in the coil may be smaller than the dynamic current

setting, particularly under high speed condition.

Standstill Current Setting

SW4 is used for this purpose. OFF meaning that the standstill current is set to be half of the selected dynamic current, and ON meaning that standstill current is set to be the same as the selected dynamic current.

The current automatically reduced to 60% of the selected dynamic current one second after the last pulse. Theoretically, this will reduce motor heating to 36% (due to $P=I^2 \cdot R$) of the original value. If the application needs a different standstill current, please contact Sunwind.

8. Wiring Notes

In order to improve anti-interference performance of the driver, it is recommended to use twisted pair shield cable.

To prevent noise incurred in PUL/DIR signal, pulse/direction signal wires and motor wires should not be tied up together. It is better to separate them by at least 10 cm, otherwise the disturbing signals generated by motor will easily disturb pulse direction signals, causing motor position error, system instability and other failures.

If a power supply serves several drivers, separately connecting the drivers is recommended instead of daisy-chaining.

It is prohibited to pull and plug connector P2 while the driver is powered ON, because there is high current flowing through motor coils (even when motor is at standstill). Pulling or plugging connector P2 with power on will cause extremely high back-EMF voltage surge, which may damage the driver.

9. Typical Connection

A complete stepping system should include stepping motor, stepping driver, power supply and controller

(pulse generator). A typical connection is shown as figure 10.

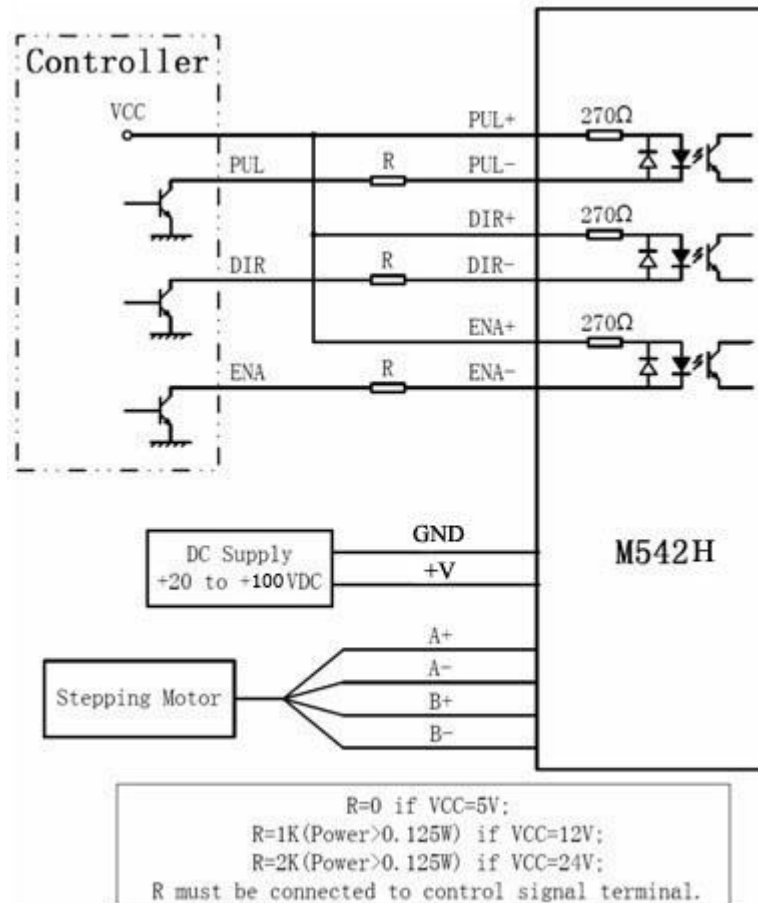

Figure 10: Typical connection

10. Sequence Chart of Control Signals

In order to avoid some fault operations and deviations, PUL, DIR and ENA signals must abide by some

rules, as shown in the following diagram (assuming J1 default setting is upward-rising edge active):

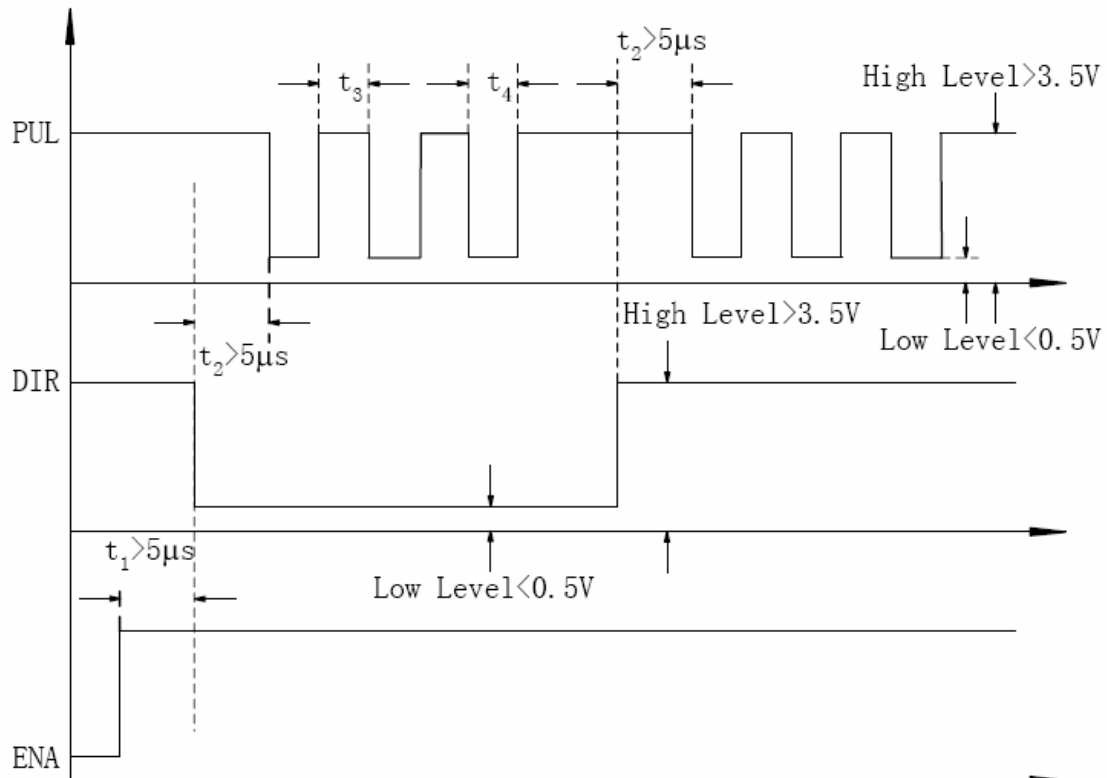

Figure 11: Sequence chart of control signals

Remark:

(1) t_1 : ENA must be ahead of DIR by at least $5\mu s$. Usually, ENA+ and ENA- are NC (not connected). See

“Connector P1 Configurations” for more information.

(2) t_2 : DIR must be ahead of PUL effective edge by at least $5\mu s$ to ensure correct direction;

(3) t_3 : Pulse width not less than $1.5\mu s$;

(4) t_4 : low level width not less than $1.5\mu s$.

11. Protection Functions

To improve reliability, the driver incorporates some built-in protections features.

Over-voltage Protection

When power supply voltage exceeds $+110VDC$, protection will be activated and power red indicator LED

will light.

Coil-ground Short Circuit Protection

Protection will be activated in case of short circuit between motor coil and ground.

Attention: Since there is no protection against power leads (+, -) reversal, it is critical to make sure that power supply leads correctly connected to the driver. Otherwise, the driver will be damaged instantly.

When power supply voltage is lower than +20VDC, the driver will not works properly.

12. Frequently Asked Questions

In the event that your M542H doesn't operate properly, the first step is to identify whether the problem is electrical or mechanical in nature. The next step is to isolate the system component that is causing the problem. As part of this process you may have to disconnect the individual components that make up your system and verify that they operate independently. It is important to document each step in the troubleshooting process. You may need this documentation to refer back to at a later date, and these details will greatly assist our Technical Support staff in determining the problem should you need assistance.

Many of the problems that affect motion control systems can be traced to electrical noise,controller software errors, or mistake in wiring.

Problem Symptoms and Possible Causes

Symptoms	Possible Problems
Motor is not rotating	No power
	Microstep resolution setting is wrong
	DIP switch current setting is wrong
	Fault condition exists

	The driver is disabled
Motor rotates in the wrong direction	Motor phases may be connected in reverse
The driver in fault	DIP switch current setting is wrong
	Something wrong with motor coil
Erratic motor motion	Control signal is too weak
	Control signal is interfered
	Wrong motor connection
	Something wrong with motor coil
	Current setting is too small, losing steps
Motor stalls during acceleration	Current setting is too small
	Motor is undersized for the application
	Acceleration is set too high
	Power supply voltage too low
Excessive motor and driver heating	Inadequate heat sinking / cooling
	Automatic current reduction function not being utilized
	Current is set too high

APPENDIX

Twelve Month Limited Warranty

Sunwind Electronics Company Limited warrants its products against defects in materials and workmanship for a period of 12 months from shipment out of factory. During the warranty period, Sunwind will either, at its option, repair or replace products which proved to be defective.

Exclusions

The above warranty does not extend to any product damaged by reasons of improper or inadequate handlings by customer, improper or inadequate customer wirings, unauthorized modification or misuse, or operation beyond the electrical specifications of the product and/or operation beyond environmental specifications for the product.

Obtaining Warranty Service

To obtain warranty service, a returned material authorization number (RMA) must be obtained

from customer service at e-mail: info@stepmotordriver.com before returning product for service.

Customer shall prepay shipping charges for products returned to Sunwind for warranty service,

and Sunwind shall pay for return of products to customer.

Warranty Limitations

Sunwind makes no other warranty, either expressed or implied, with respect to the product.

Sunwind specifically disclaims the implied warranties of merchantability and fitness for a

particular purpose. Some jurisdictions do not allow limitations on how long and implied warranty

lasts, so the above limitation or exclusion may not apply to you. However, any implied warranty of

merchantability or fitness is limited to the 12-month duration of this written warranty.

Shipping Failed Product

If your product fail during the warranty period, e-mail customer service at info@stepmotordriver.com to

obtain a returned material authorization number (RMA) before returning product for service.

Please include a written description of the problem along with contact name and address. Send

failed product to distributor in your area or:

Sunwind Electronics Company Limited.

Add:7th Floor,Block H,Juyin Industrial Park,Ganli Road 1#,Buji,Shenzhen,China.P.C.518112

Also enclose information regarding the circumstances prior to product failure.